

**POMPE MANUALI PER GRASSO
PER IMPIANTI A DOPPIA LINEA**

**MANUAL PUMPS FOR GREASE
FOR DUAL LINE SYSTEMS**

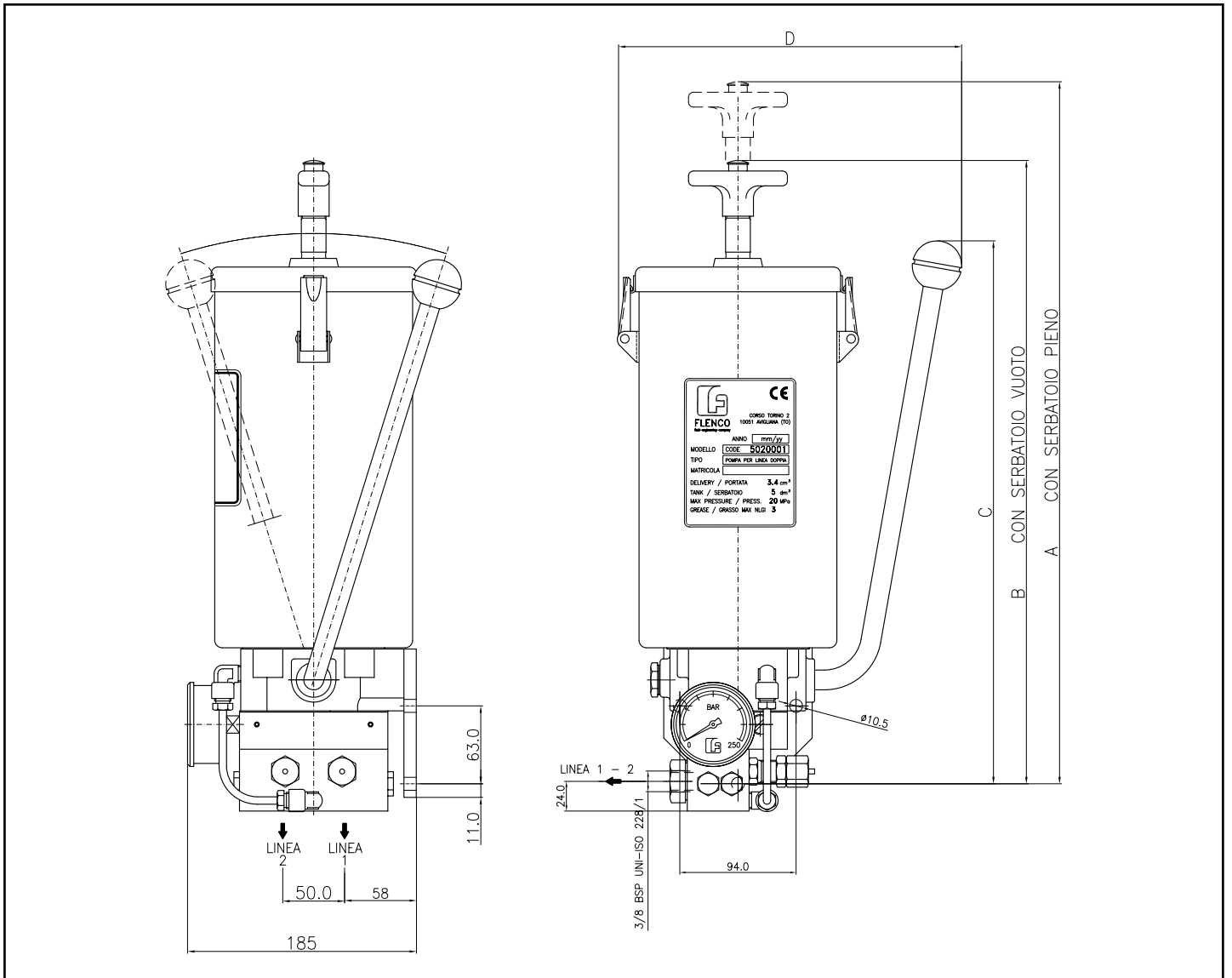

CARATTERISTICHE TECNICHE:

Portata azionamento: 3,4 cm³
 Capacità serbatoio: 5 kg - 2 kg - 1 kg
 Pressione di inversione: 3-30 MPa
 Pressione utilizzo max: 20 MPa

TECHNICAL CHARACTERISTICS:

Start up output: 3,4 cm³
 Tank capacity: 5 kg.- 2 kg.- 1 kg.
 Reversing pressure: 3-30 MPa (435-4350 PSI)
 Max working pressure: 20 MPa (2900 PSI)

Codice Code	Capacità serbatoio / Tank capacity Kg.	Dimensioni / Dimensions			
		A	B	C	D
5020001	5	745	504	440	278
5020002	2 con molla / with spring	866	577	439	272
5020005	1 con molla / with spring	462	355	439	272

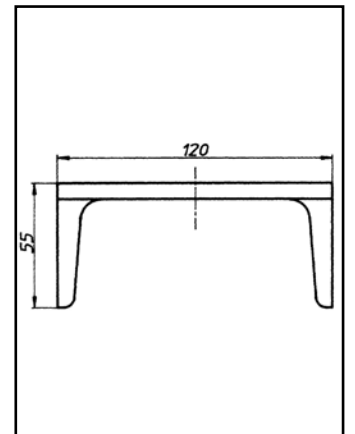

Per il fissaggio delle pompe serie 5020...
 Peso kg 3,70
 Vite **Code 9241934**
 Dado **Code 9169032**
 Rosetta **Code 9264066**
 Piastre a saldare a U **Code 8278003**

For 5020 series pumps fixing 5020...
 Weight kg.3,70
 Screw **Code 9241934**
 Nut **Code 9169032**
 Ring **Code 9264066**
 Plates to be U welded **Code 8278003**